

CHEERBOT

Make a robot that reacts to loud sounds by waving its arms in a cheer!

Tools & Materials

Included in kit:

- CheerBot Templates
If you need to print new templates, you can download them here:
<https://www.okdo.com/p/okdo-microbit-build-a-paper-robot-kit/>
- Standard Micro Servo (EF92A, micro:servo 180°)
- 3x Crocodile to Male Jumper Pin Cables
- micro:bit v2 Board
- Micro USB Cable

Not included in kit:

- Computer
- Scissors or Craft Knife
- Glue
- Tape



Cheerbot templates and instructions © Jasmine Florentine 2022

This work is licensed under a Creative Commons Attribution-NonCommercial-ShareAlike 4.0 International License: <https://creativecommons.org/licenses/by-nc-sa/4.0/>

The included templates and instructions are made available under a CC BY-NC-SA-4.0 license. This means you are free to copy, print, translate, and remix elements of the templates as long as it is not for commercial purposes. We only require that you attribute Jasmine Florentine and OKDo and that any derivative works (such as translations and lesson plans) also use the same CC BY-NC-SA-4.0 license.



1

Start by cutting all the pieces out of first page of the template. You might find it easiest to use a craft knife for the cutouts (the parts shaded in grey). Make sure to have an adult help if you use a craft knife.

If you have trouble cutting the long slot, continue to step 2 instead.

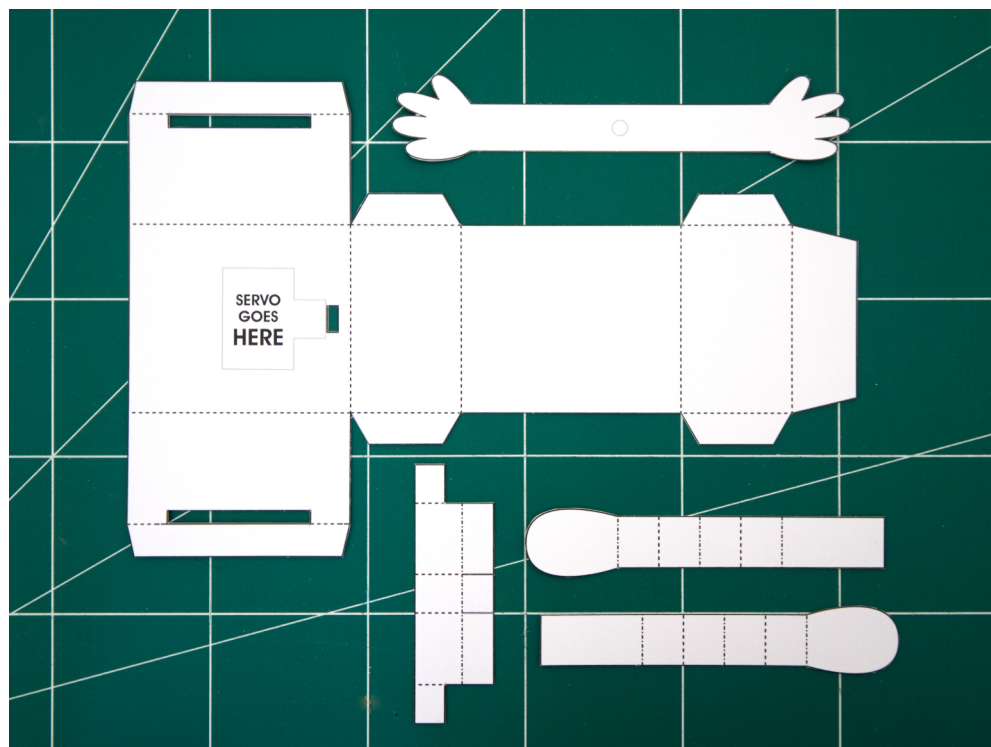
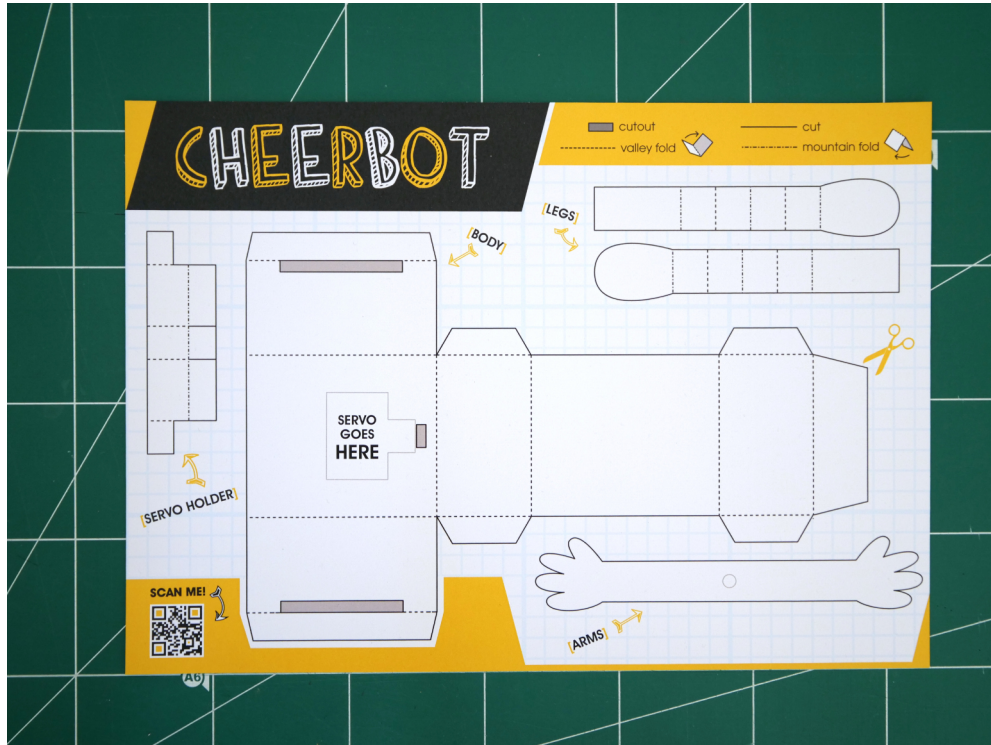

2

(If you already cut the slots without difficulty, skip this step).

If you're having trouble cutting the slots, you can instead use scissors to cut along the red outline in the picture below. The final result will be a tiny bit flimsier, but you'll still have enough room on the remaining part of the tabs to glue everything together.

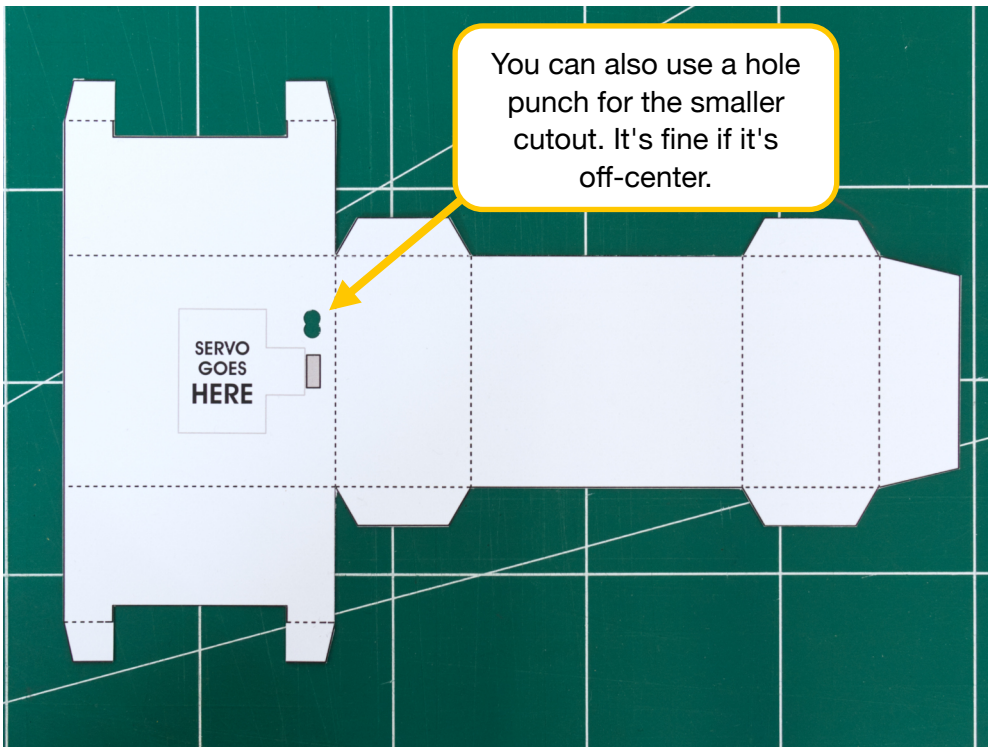
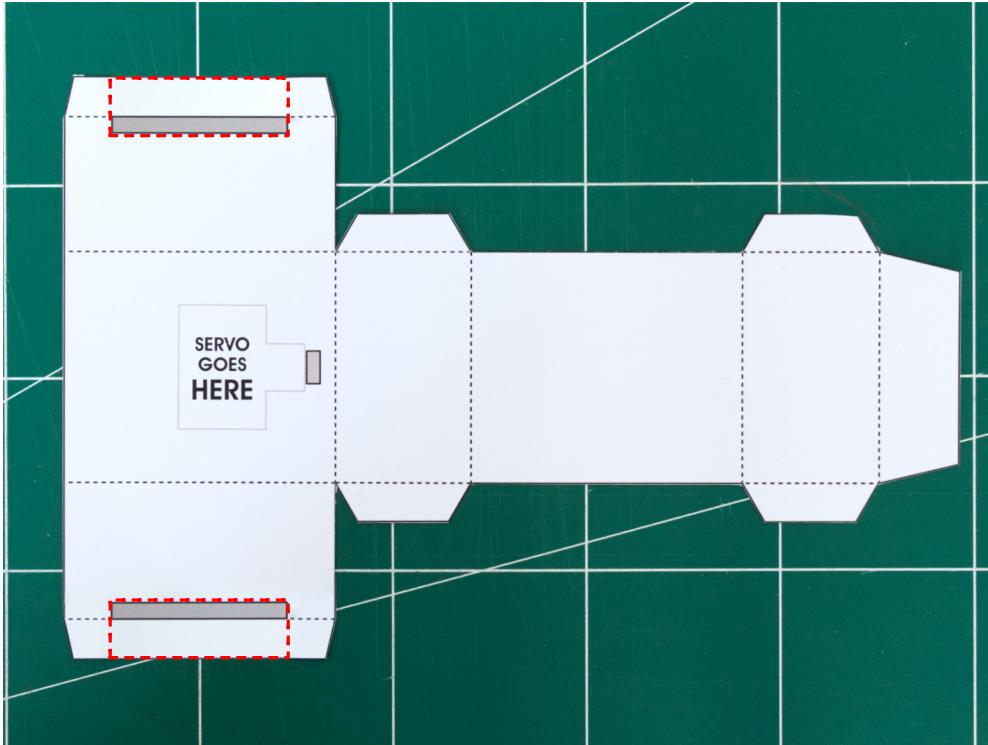

3

Pre-crease all the fold lines. This will make assembly easier later on.

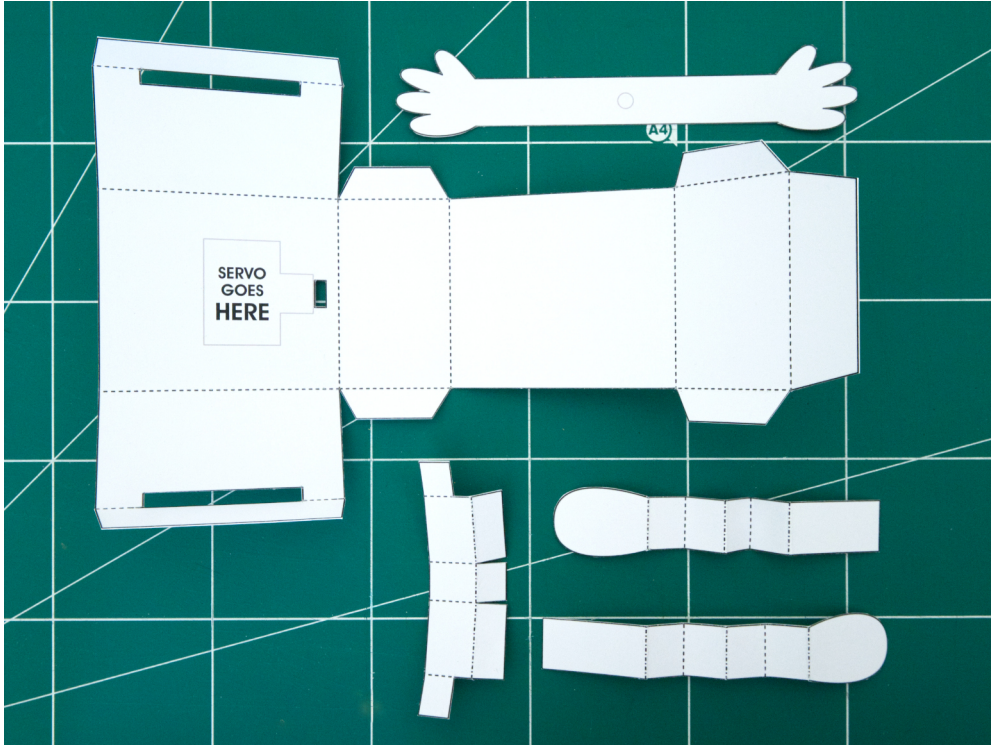
**4**

You can decorate Cheerbot when it's finished, but you might find it easier to color some of the parts while it's still disassembled. (I usually color the parts on the backside, since all the fold lines will be hidden on the inside). In this case, I decided to decorate at the end.

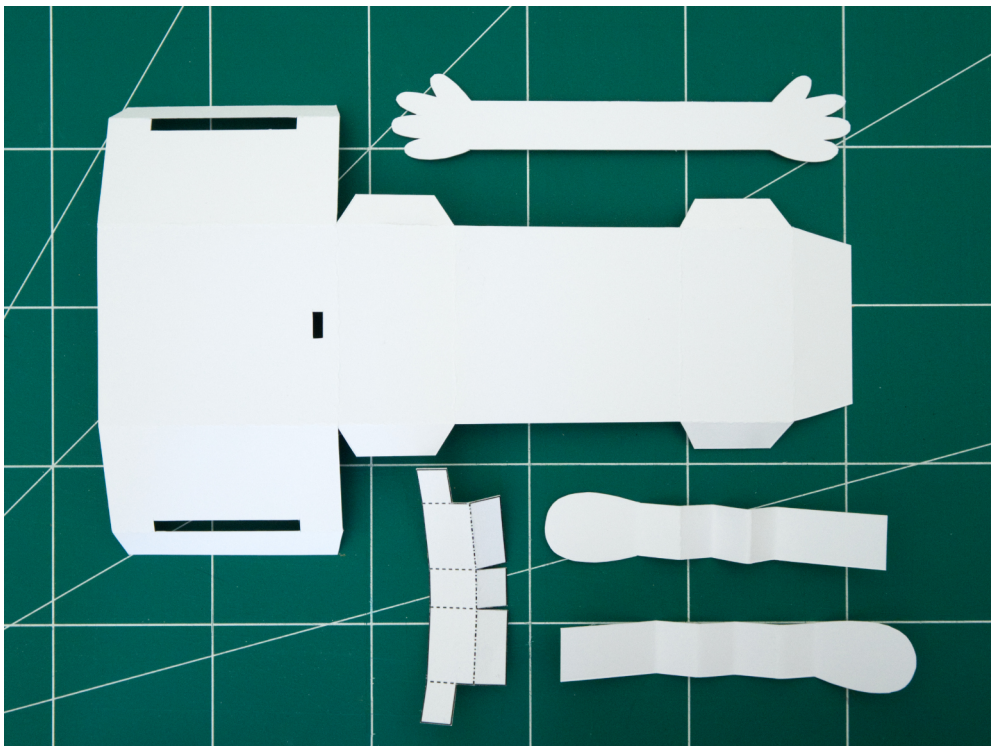

5

Tape a servo horn to the middle of the arms (where the mark is).

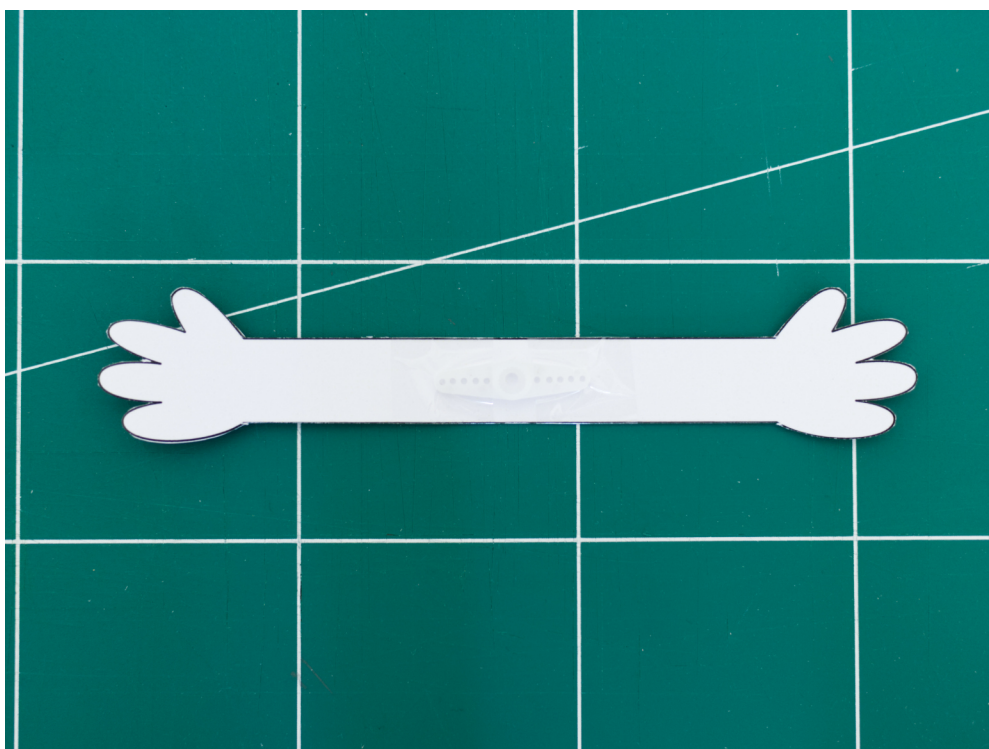
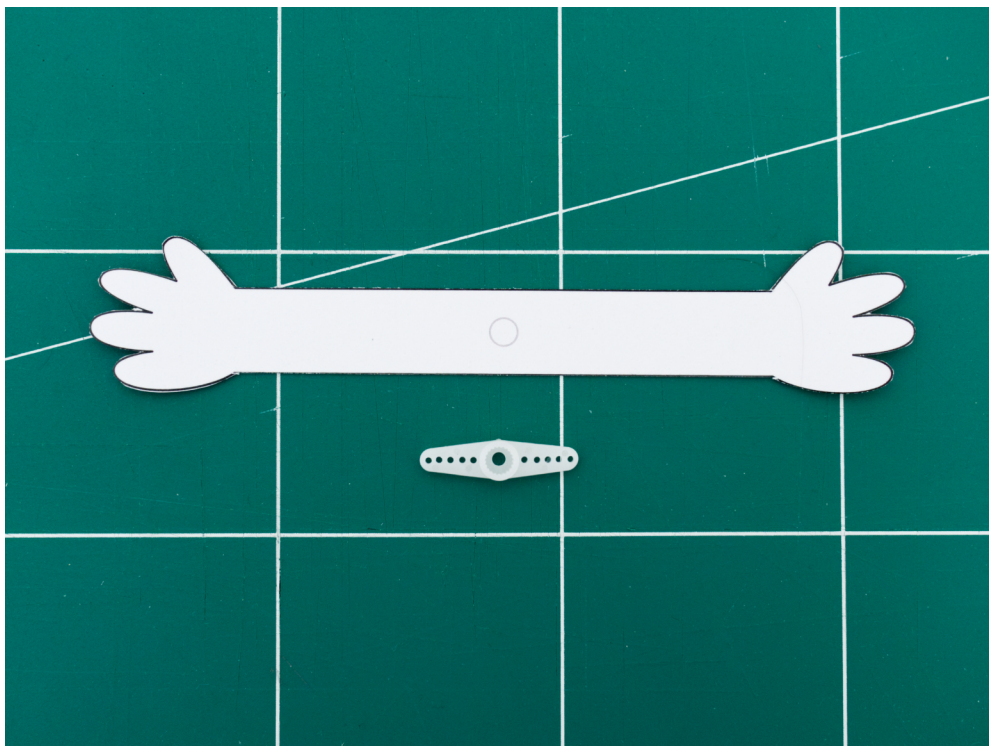

6

Glue or tape the servo holder around the servo. You don't need to put glue on the servo itself, just on the paper tabs that wrap around the servo body.

Note: For this project, make sure you're using the **standard 180° servo** (the one labeled EF92A).

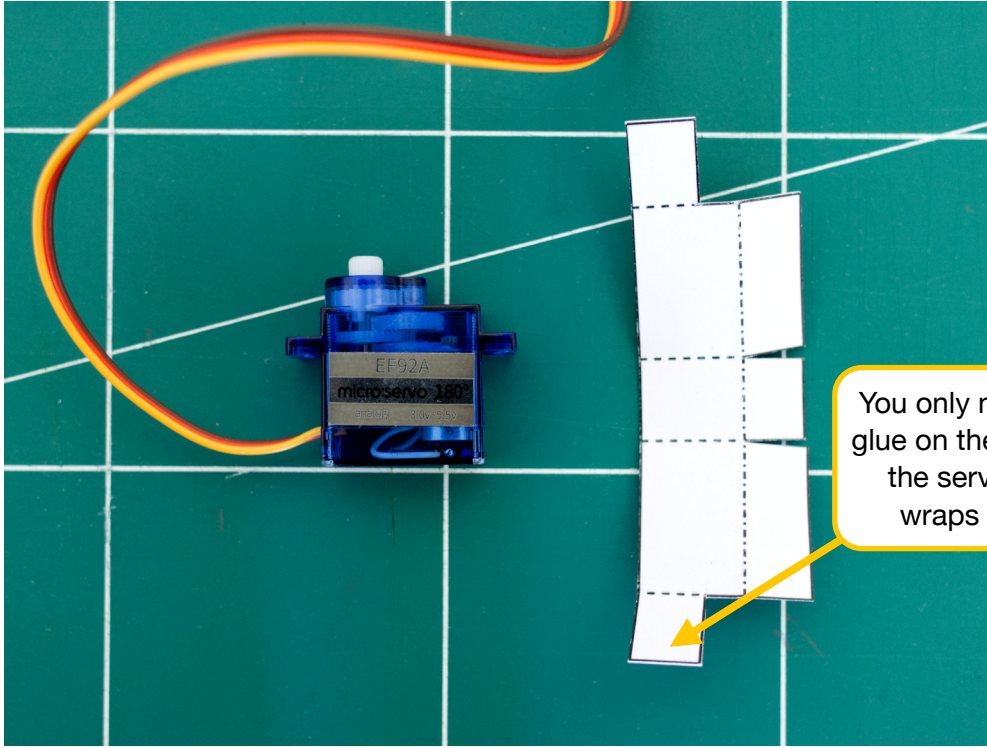

You only need to put glue on the tab where the servo holder wraps around.

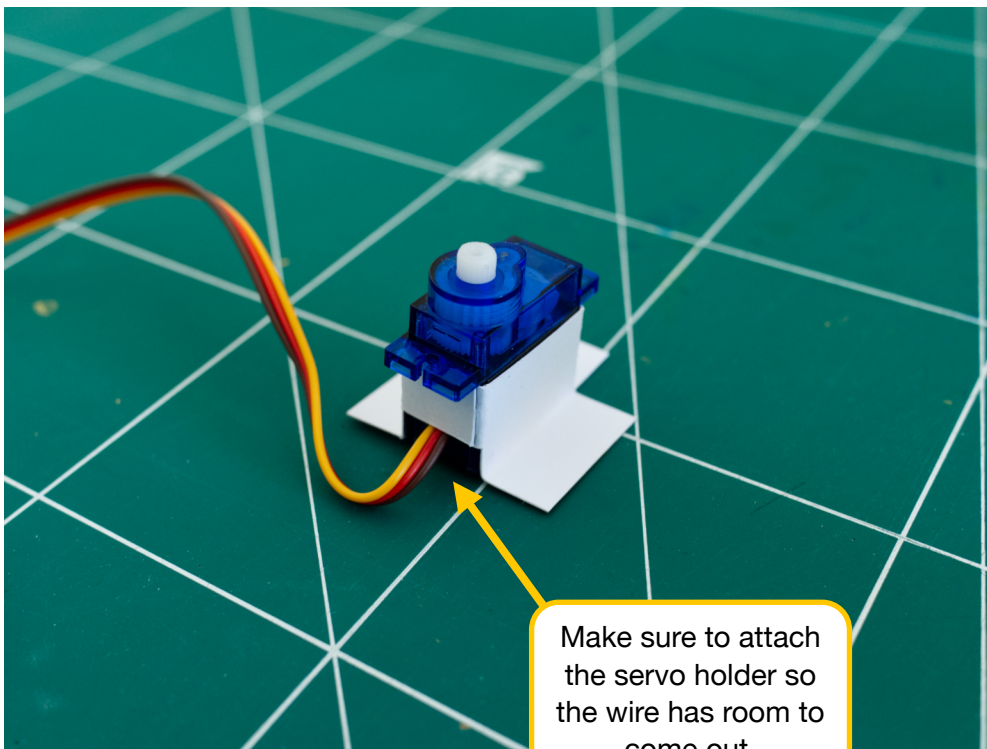

Make sure to attach the servo holder so the wire has room to come out.

7

Glue or tape the servo in place where shown. Once again, you don't need to put glue on the actual servo — you can just put it on the paper tabs of the servo holder.

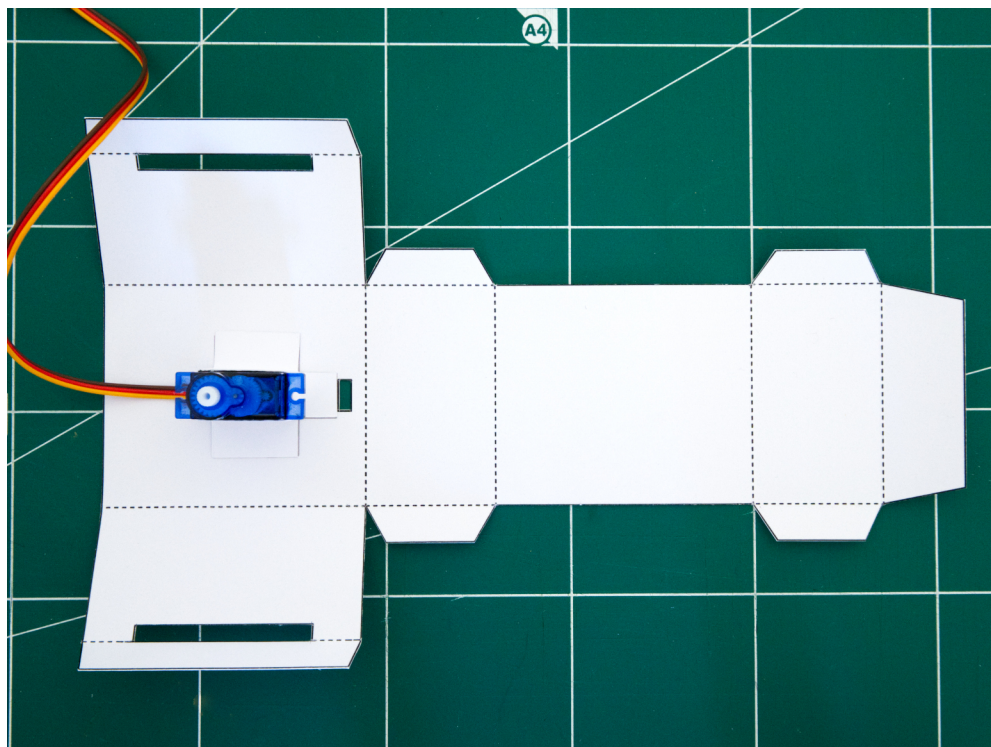
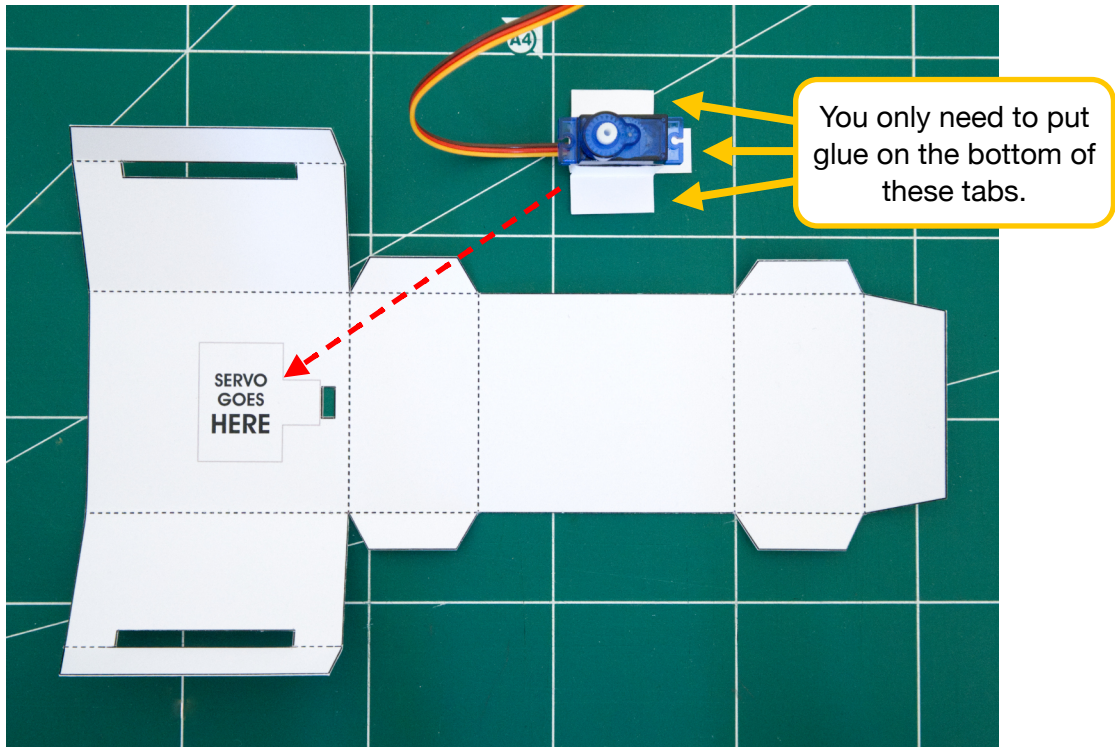

8

Fold and glue (or tape) the back and bottom of the body together.

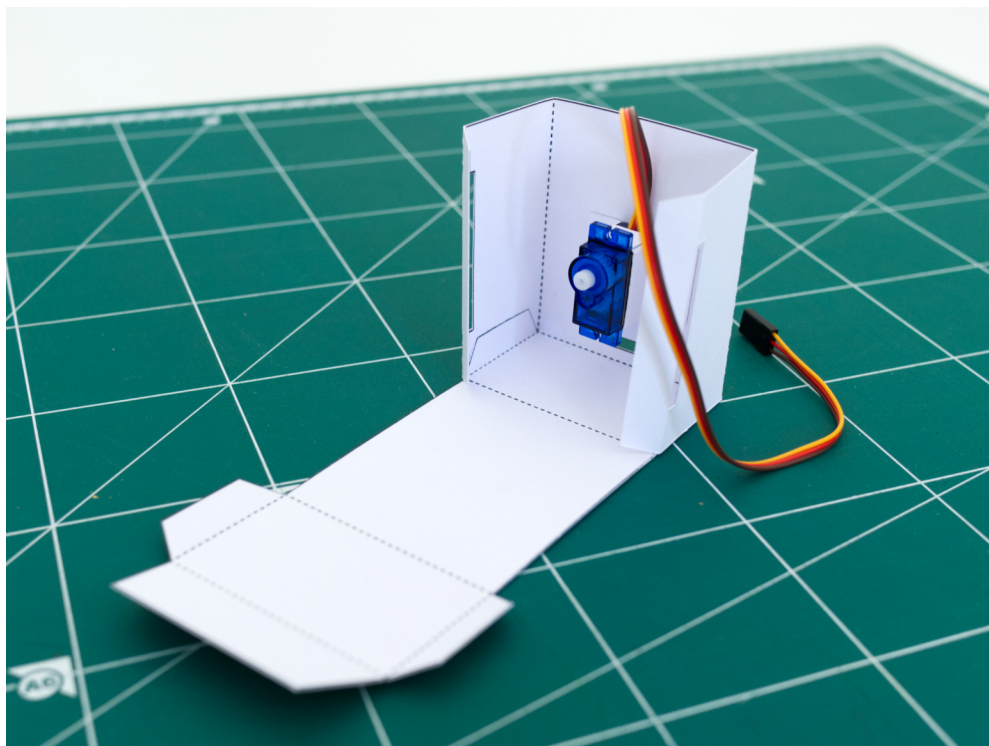

9

Thread the servo wire through the cutout in the body, and use a small piece of tape to hold it in place.

Tape the servo wire to hold it in place.

Thread the wire through the cutout.

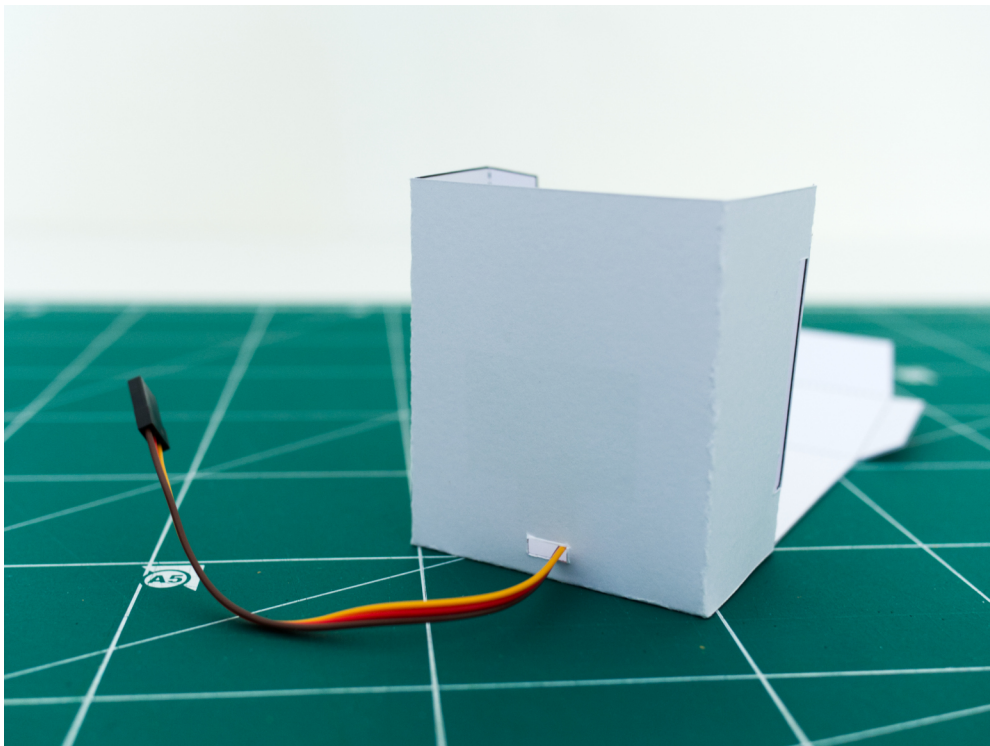
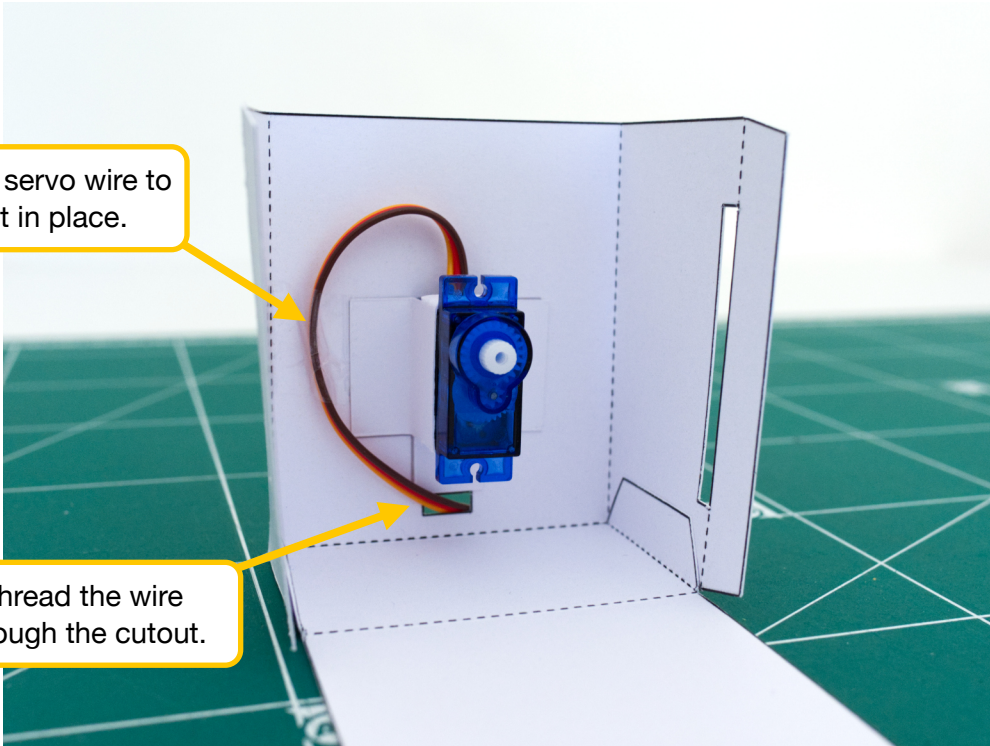

10

We need to set the angle of the servo before we finish making the rest of the body. To do that, we'll need to connect the electronics and program the micro:bit.

Connect 3 of the the crocodile to male jumper pin cables to the servo header. You can use any color of crocodile cables, but if you match the color of the servo wires to the crocodile cables, it will make it much easier to keep track of the connections.

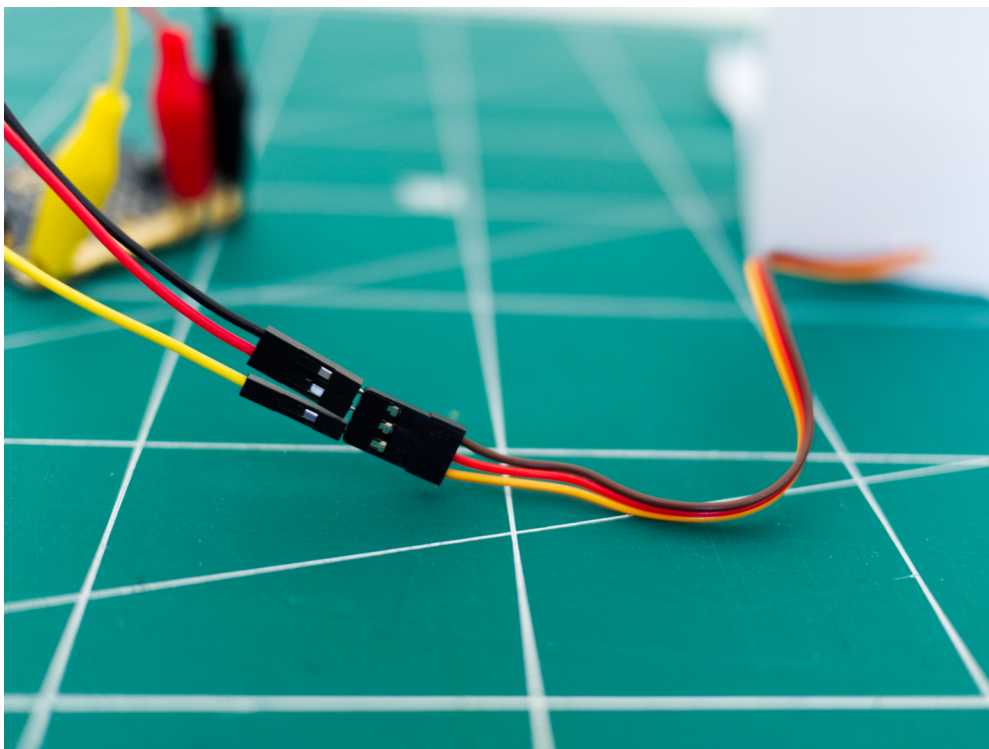
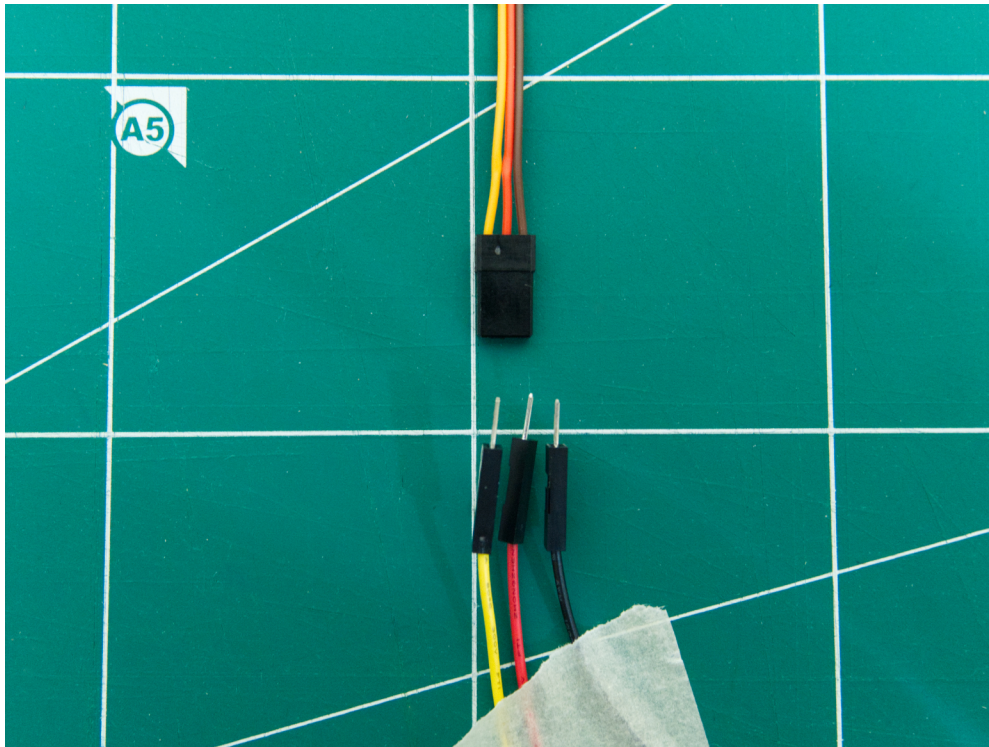

11

Connect the crocodile clips to the micro:bit. Make sure that they are connected as follows:

- Crocodile clip connected to the YELLOW servo wire → micro:bit Pin 0
- Crocodile clip connected to the RED servo wire → micro:bit 3V
- Crocodile clip connected to the BROWN servo wire → micro:bit GND

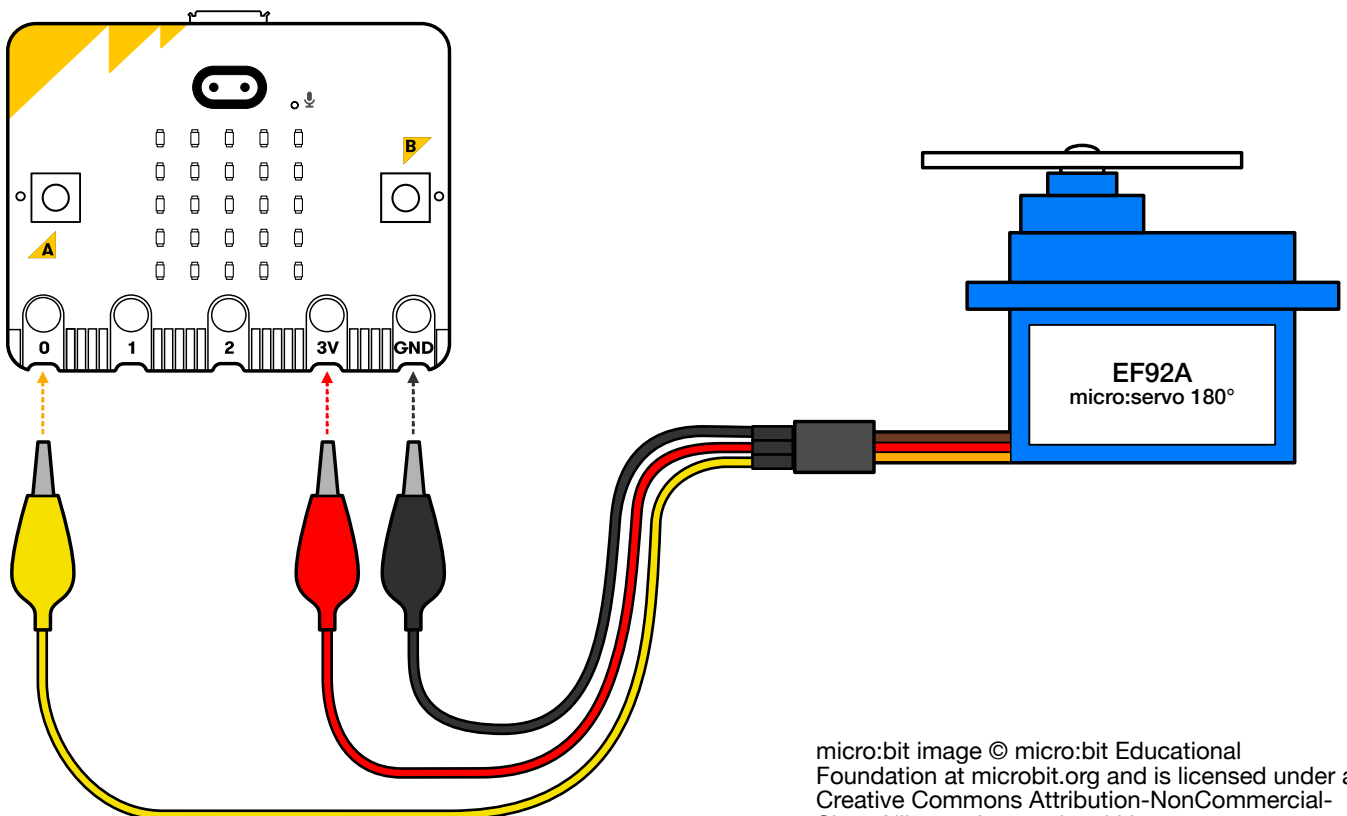
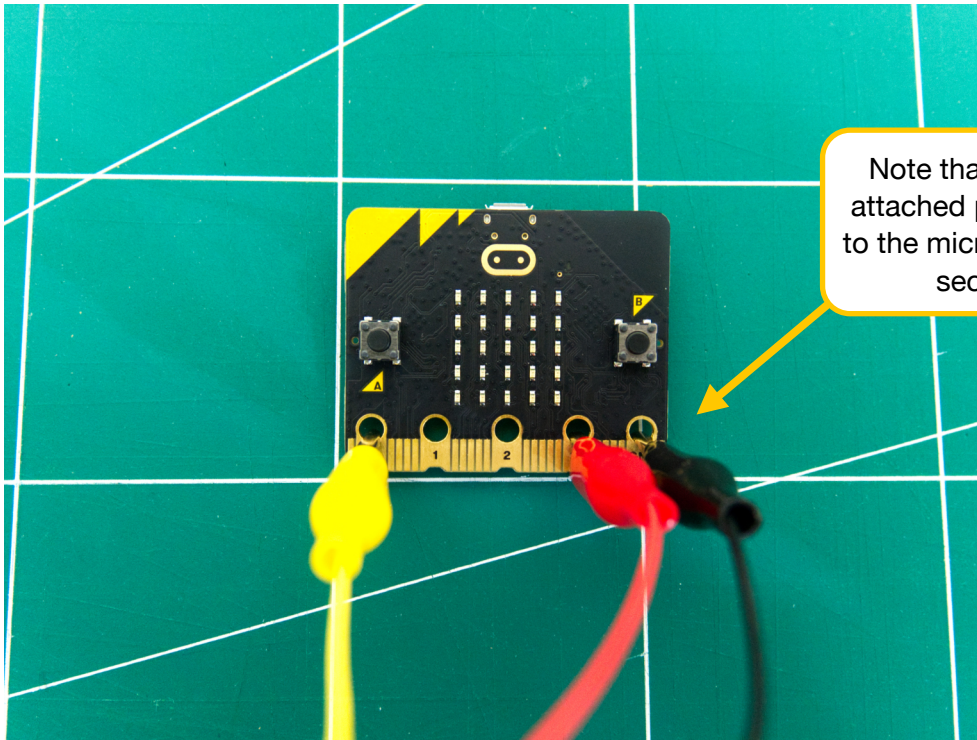

micro:bit image © micro:bit Educational Foundation at microbit.org and is licensed under a Creative Commons Attribution-NonCommercial-ShareAlike 4.0 International License

12

Connect the micro:bit to your computer using the micro USB cord. The cord will be used both to transfer the code and to supply power to the micro:bit and the servo.

13

Get the code from here:

https://makecode.microbit.org/#pub:_AkV9p8JT9VWd

The "set loud sound threshold" block tells the micro:bit how loud a sound needs to be to be considered "loud" enough to trigger the cheering movement. You may need to make this number bigger or smaller depending on how loud your surroundings are.

If you're in a loud environment, you may want to use the code in the Step 14 instead to make sure the sound sensor isn't accidentally triggered.

You may need to experiment with making this number bigger or smaller.

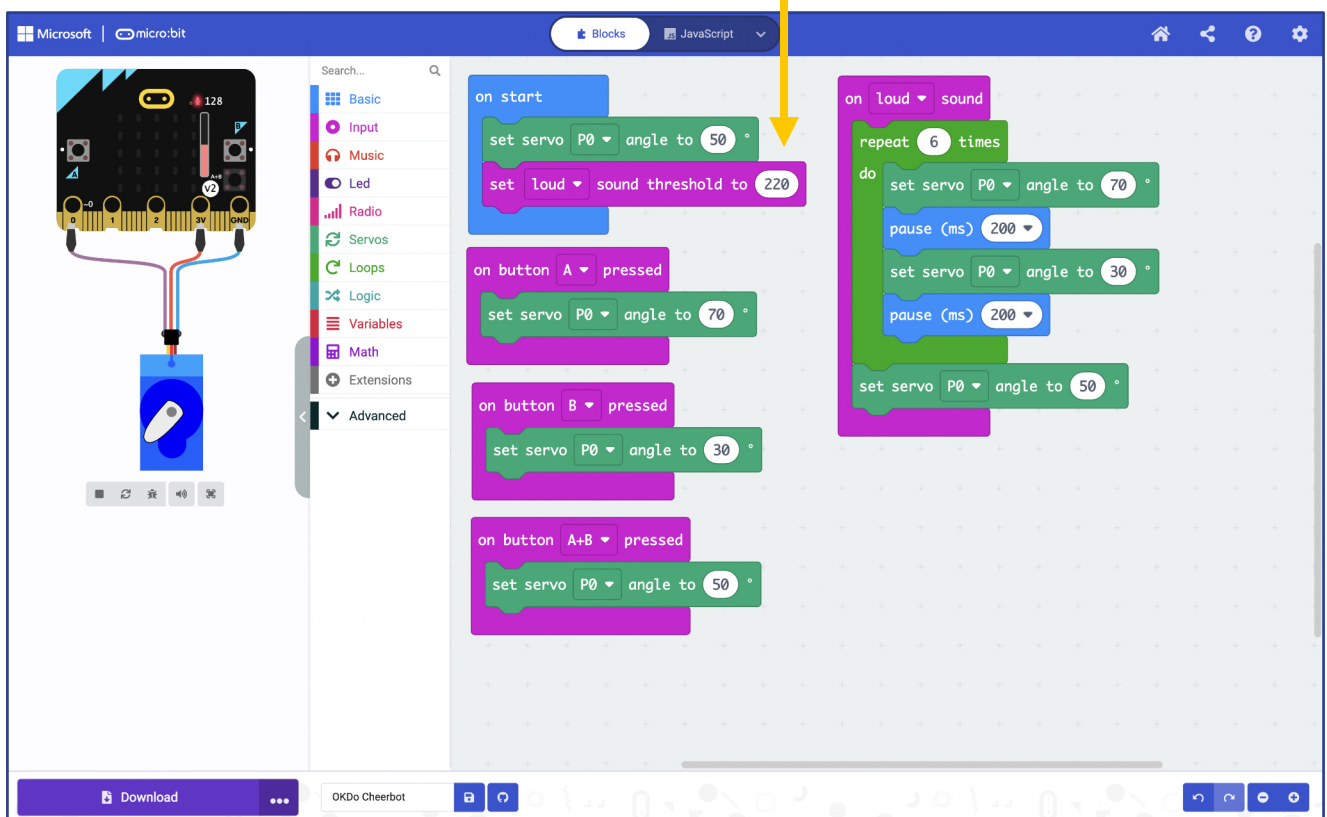

14

This is a modified version of the code that requires you to press the logo AND make a loud sound to trigger the cheering movement. That way, it's harder to set off the cheering movement by accident.

To adjust how loud the sound needs to be to trigger the movement, change the number in the "sound level \geq 220" block to be higher or lower.

https://makecode.microbit.org/#pub:_0qAhWEdWU5we

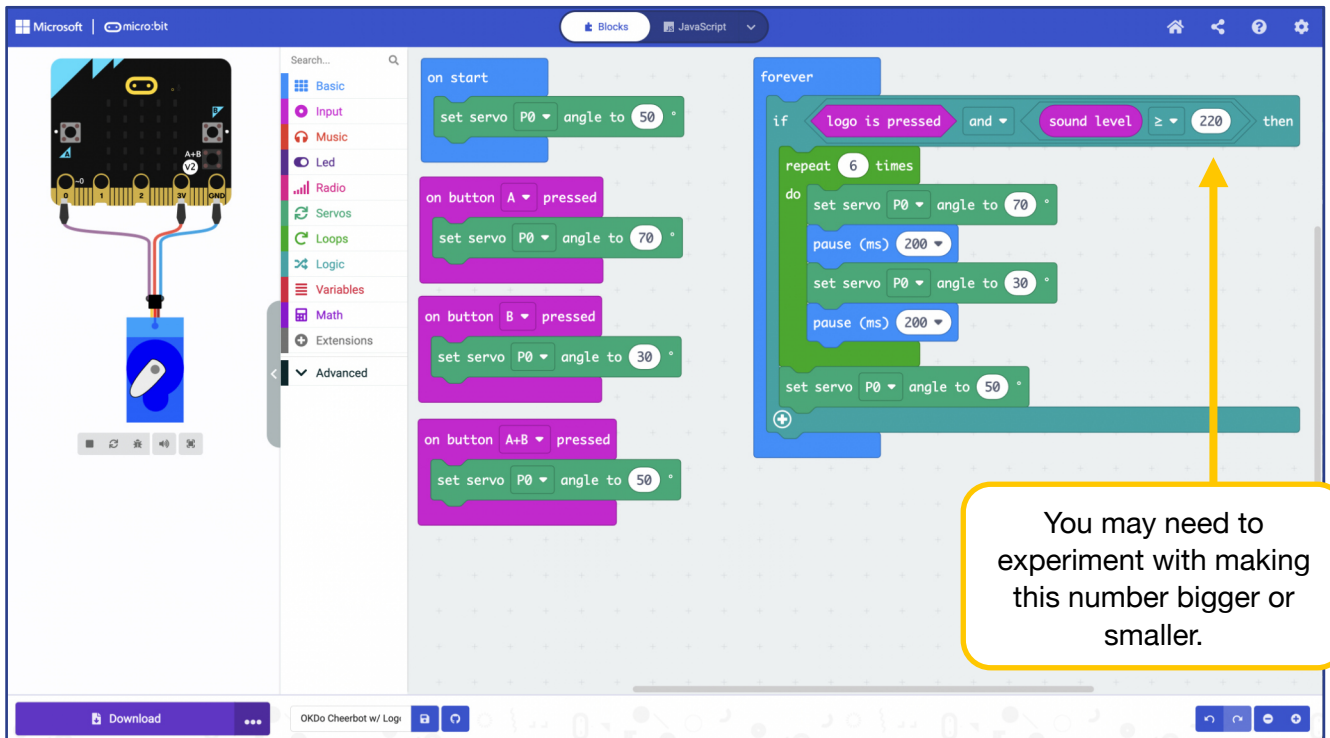
**15**

Upload the code to the micro:bit using the following instructions (choose in the instructions what type of computer and browser you're using for more specific directions):

<https://microbit.org/get-started/first-steps/set-up/>

or

<https://makecode.microbit.org/device/usb>

16

With the electronics connected, press the A+B buttons together to center the servo's position. That way, when you attach the arm, it will start at the right position and won't get caught at some weird angle in the slot cutouts.

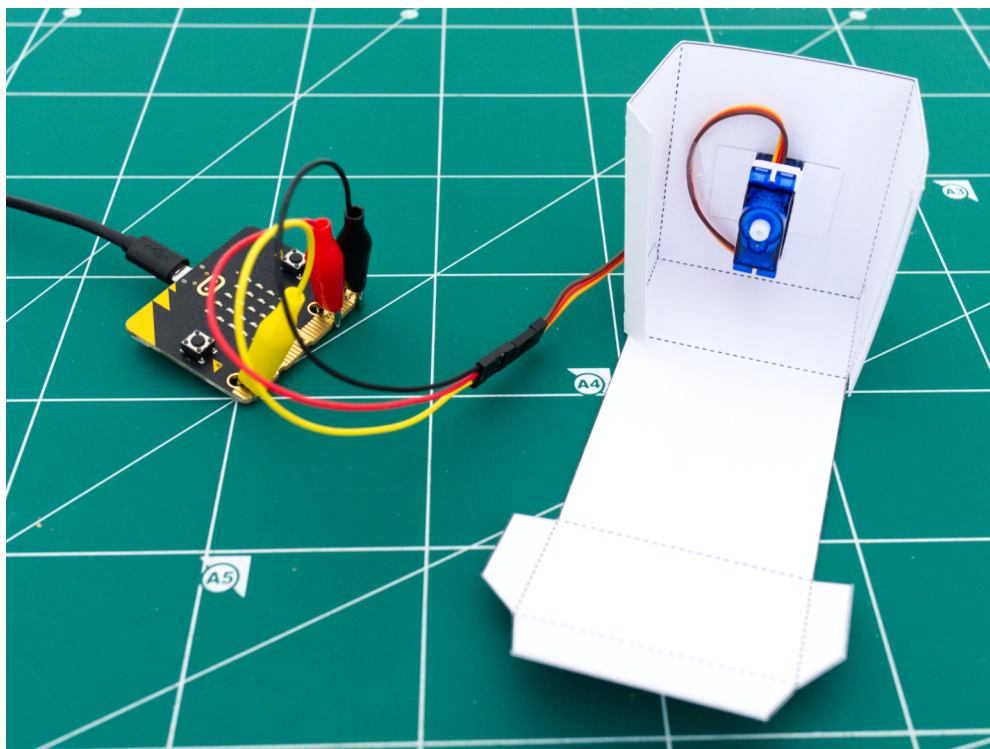

17

Slide the arm in through the slot cutouts with the servo horn facing inwards (towards the servo).

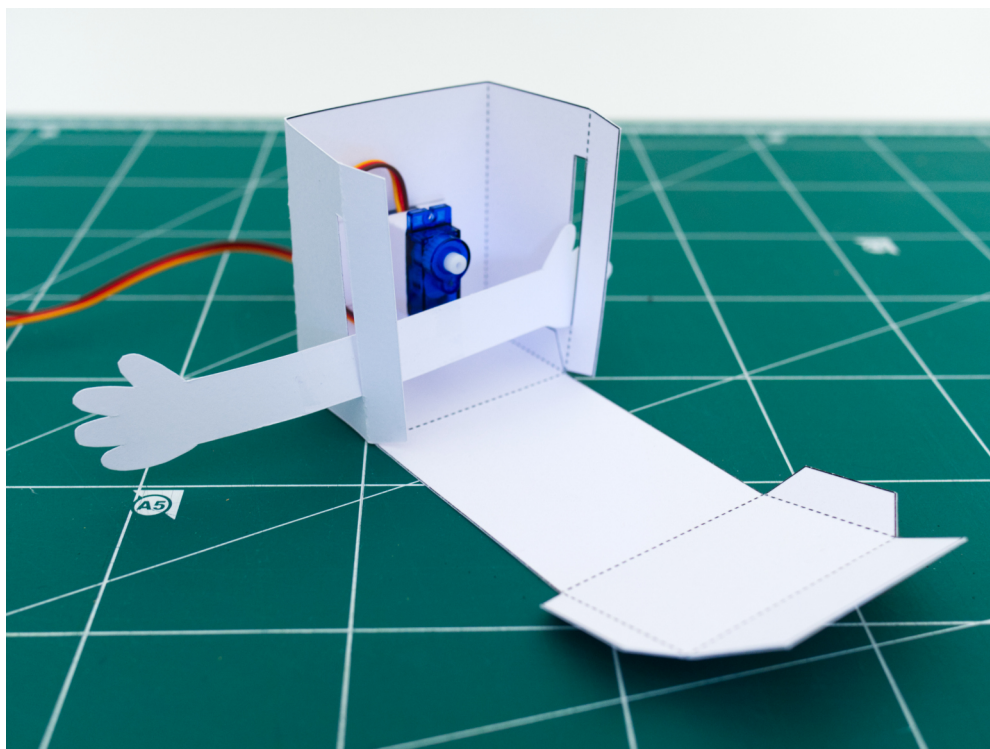

18

Push the servo horn onto the servo with the arm in the horizontal position as shown.

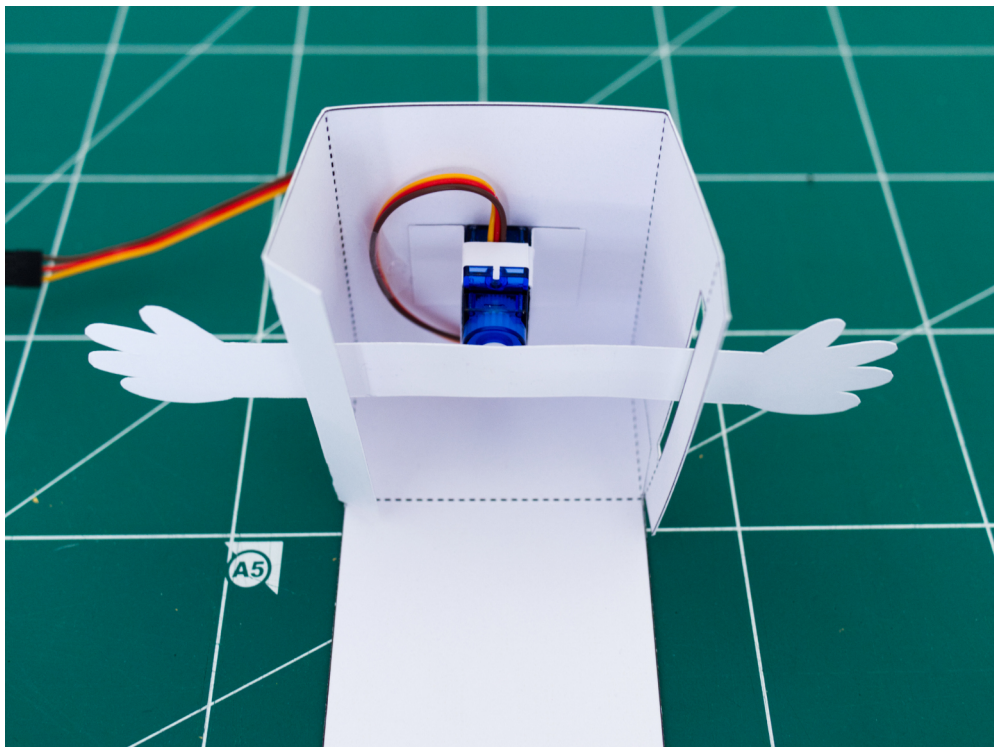
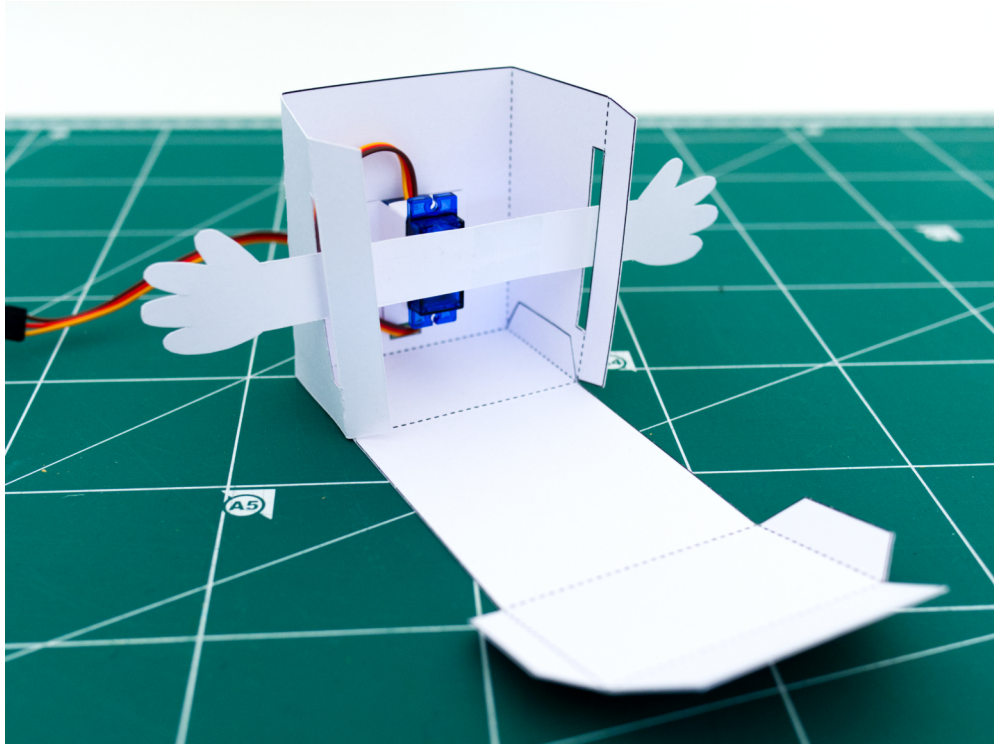

19

Test the arm's range of motion by pressing A and then B. If the arm collides with either end of the slot, you may need to adjust the angle in the code.

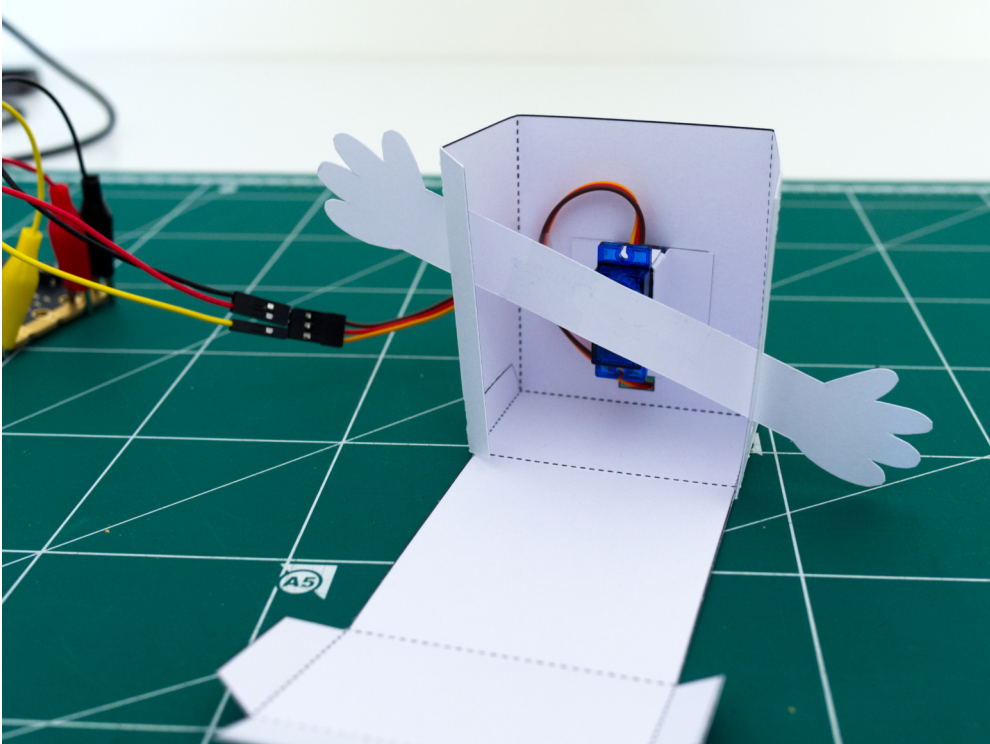

20

Now that you've attached the arm and tested the servo, fold and glue (or tape) the front of the body. You can unplug the servo in the meantime.

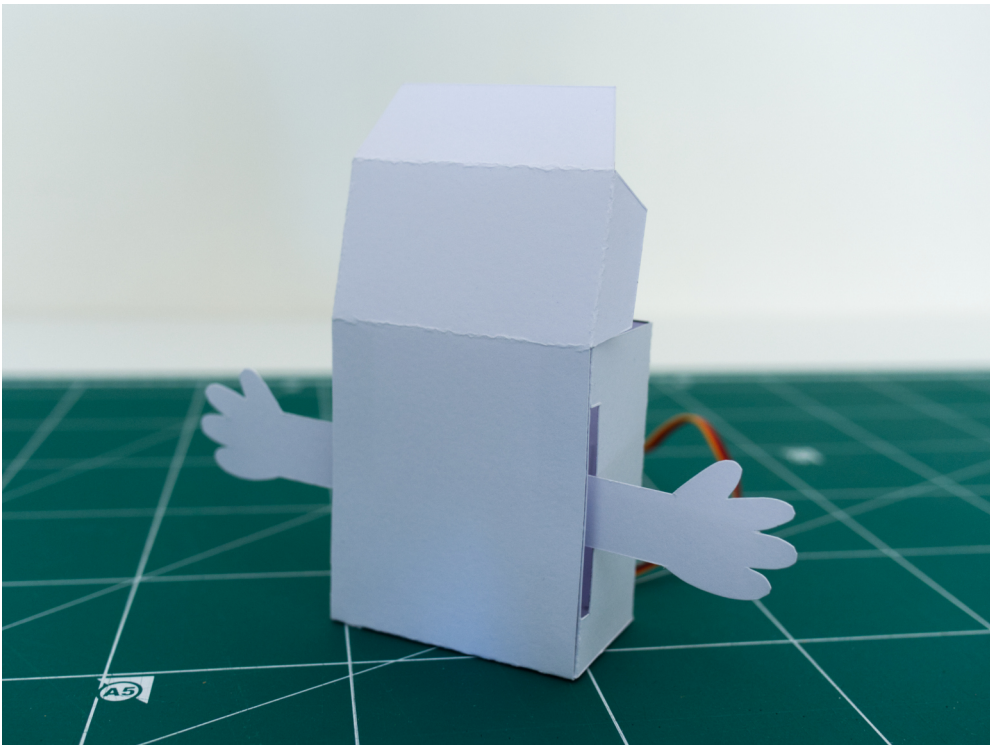

21

Fold the top of the body shut. The top should hold in place even without glue or tape, if you want to leave the inside accessible (in case you need to fix something, or just want to show off how it works from the inside).

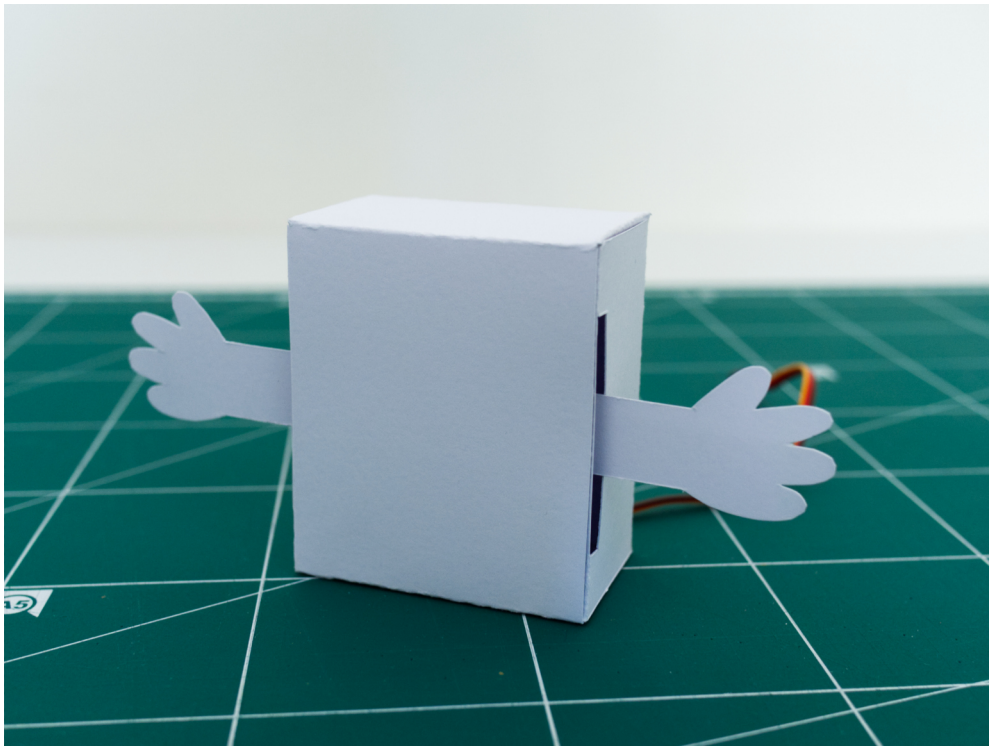

22

Glue the legs to the bottom of the body.

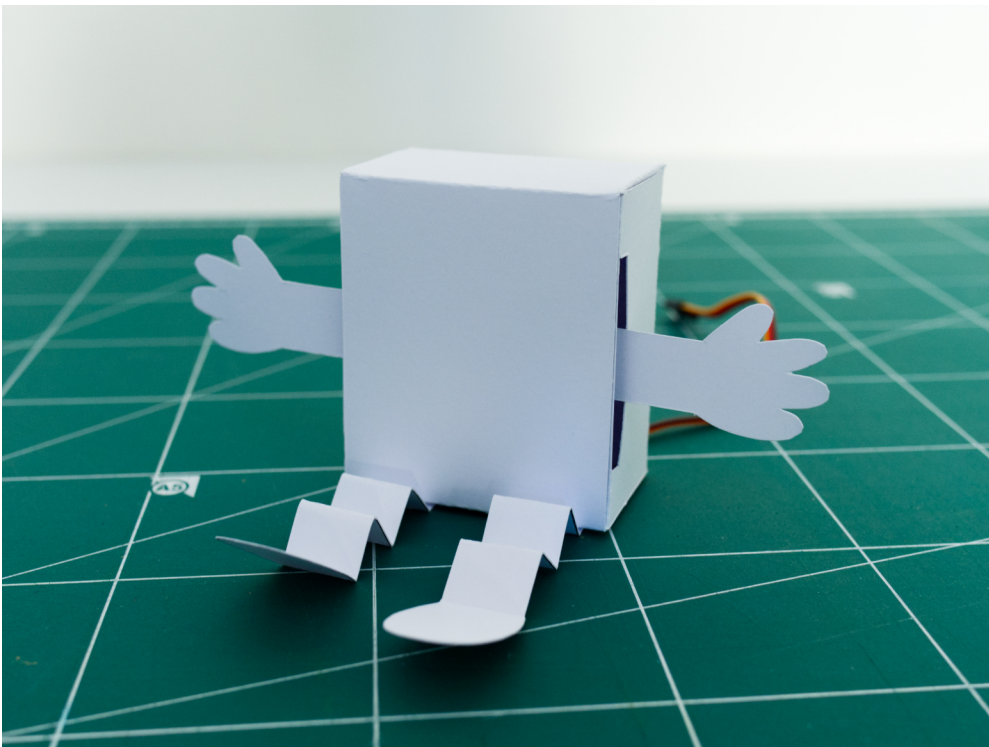

23

Give your Cheerbot a face and decorate it! You can draw or make your own face and props, or use the provided template. I gave mine pom-poms made out of origami paper.

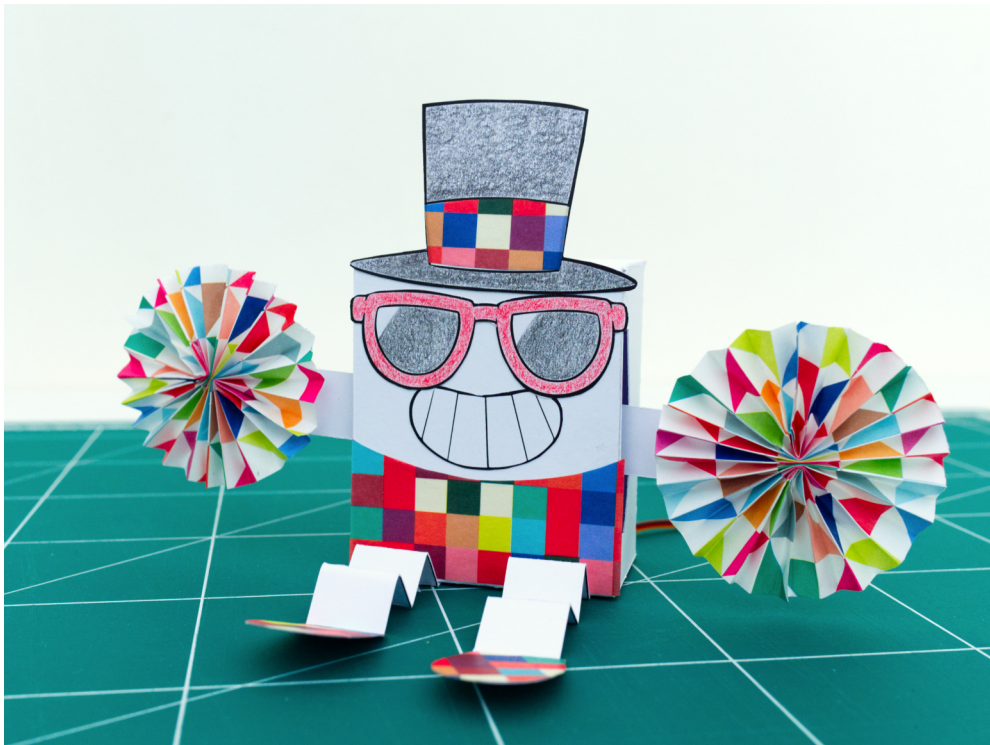
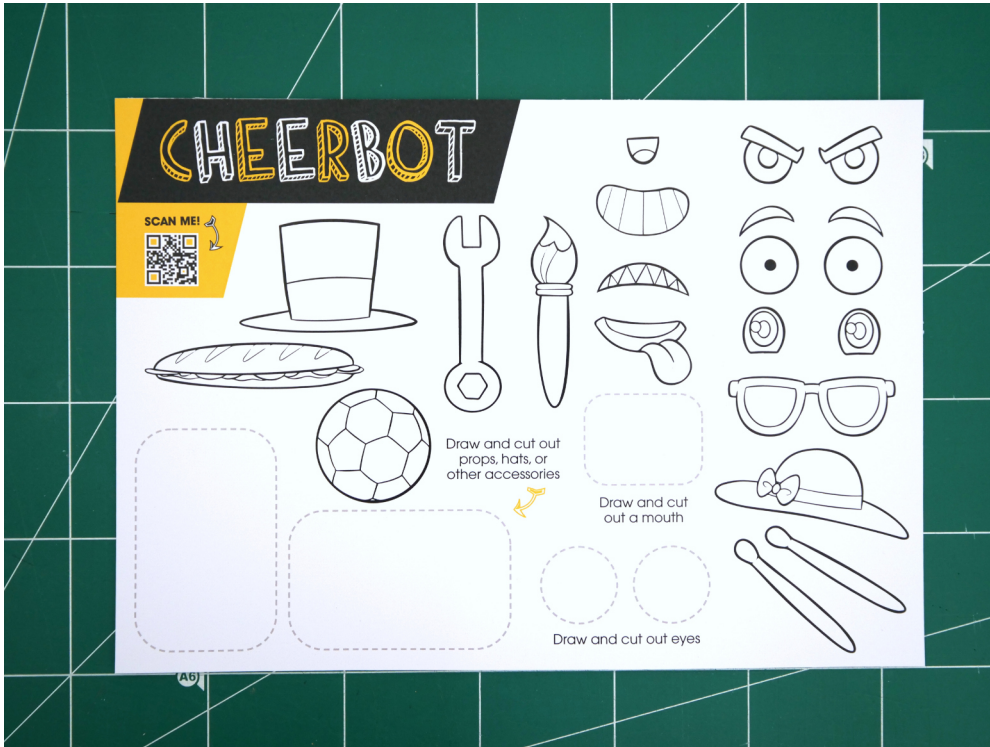

24

Reconnect the electronics if you disconnected them earlier, then test it out. Make a loud noise for Cheerbot to cheer along to! Here's a video of it in action: <https://youtu.be/C5459no6u5g>



25

Experiment! Can you change the MakeCode to make Cheerbot cheer for longer? Or wave its arms faster? What about using a "play sound" block so Cheerbot can join in the noise-making?

Bonus

Turn your Cheerbot into a Ticklebot!

You can easily convert your Cheerbot into a Ticklebot that reacts to being touched or tickled! You'll need the following materials:

- Tin Foil or Conductive Tape
- 1x Crocodile Clip (included in the kit)

1

Cut a piece of tin foil (or conductive tape) the length of Cheerbot's leg. If you want both legs to be ticklish, cut out a second piece of tin foil to glue to the other leg as well.

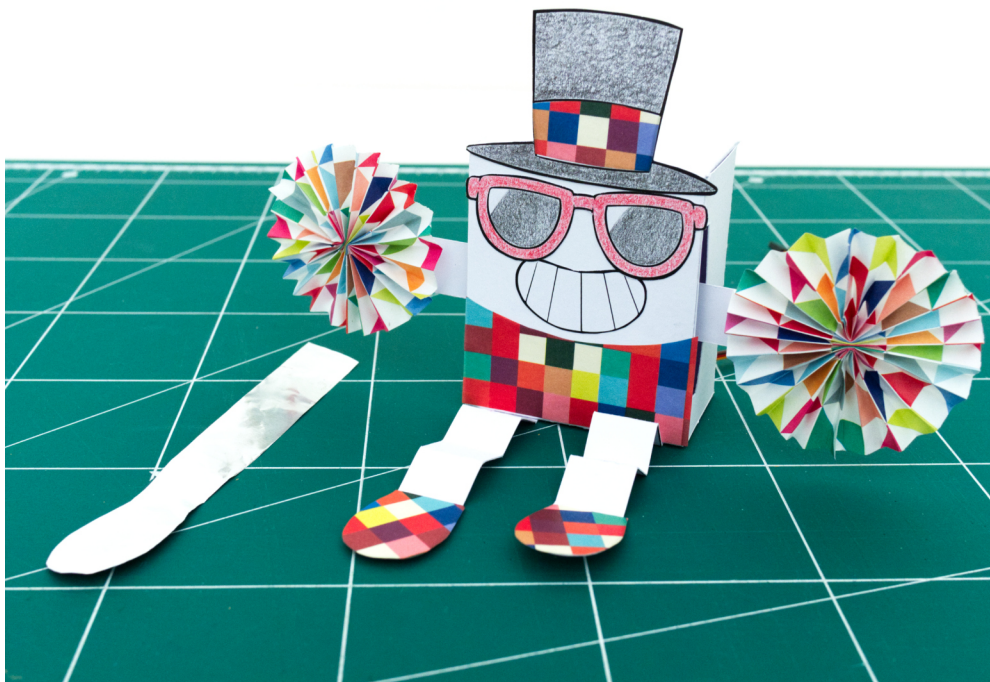

- 2** Glue the tin foil to the bottom of one or both legs (or stick a strip of the conductive tape).



- 3** Add another small piece of tin foil or conductive tape at the center-bottom of the body as shown. If you want both legs to be ticklish, make sure that this smaller piece touches the foil on both legs.



4

Connect the crocodile clip through the servo cutout so that it touches the tin foil.

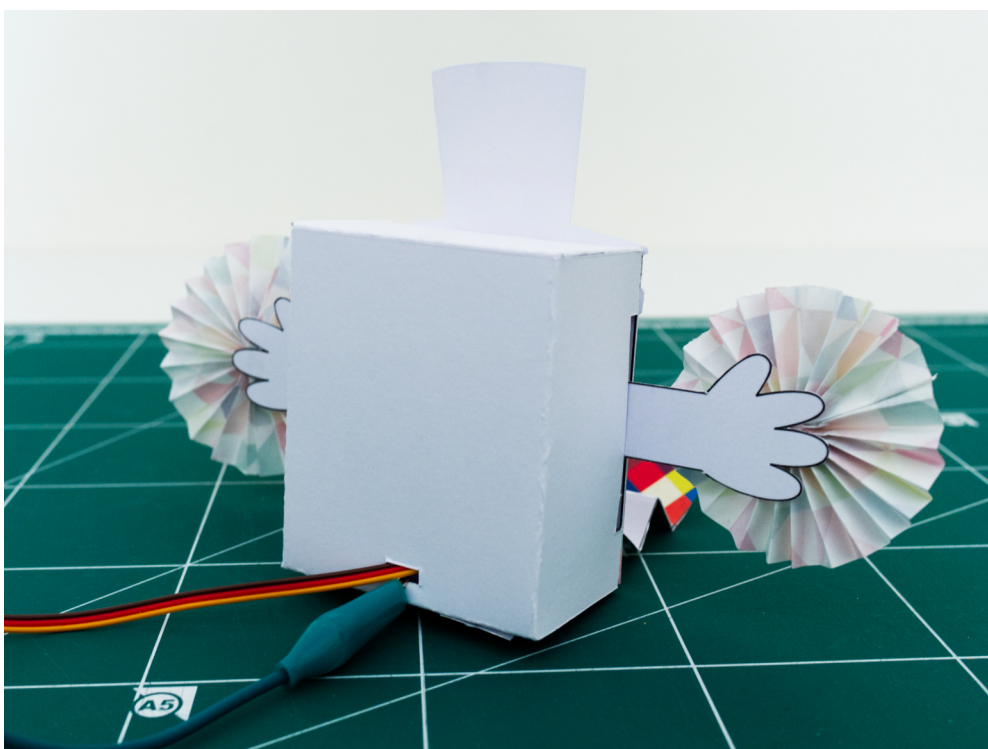
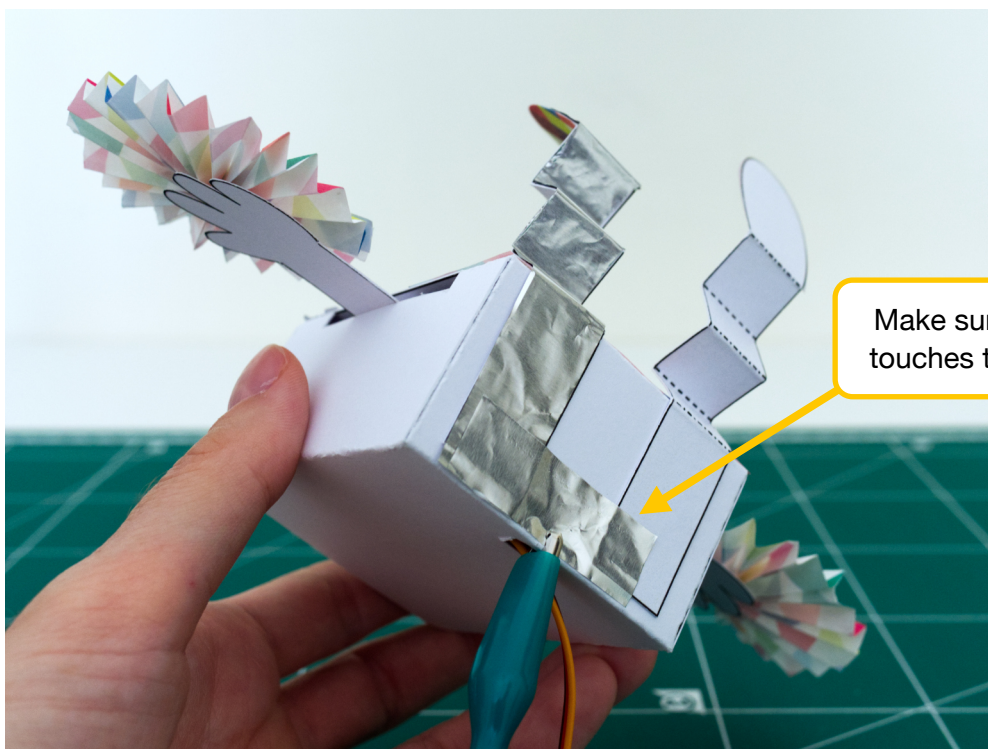

- 5 Connect the other end of the crocodile clip to the micro:bit at Pin 1.

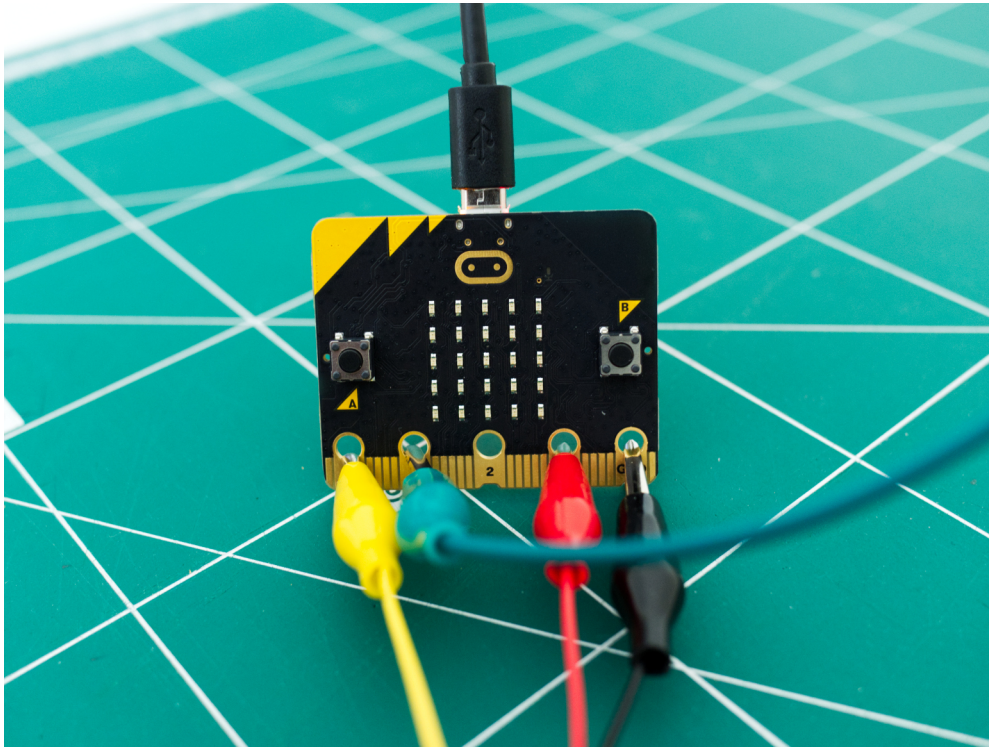

- 6 Connect the micro:bit to your computer using the micro USB cord. The cord will be used both to transfer the code and to supply power to the micro:bit and the servo.

- 7 Get the code from here:
https://makecode.microbit.org/#pub:_W9rEFR9A0Cgh

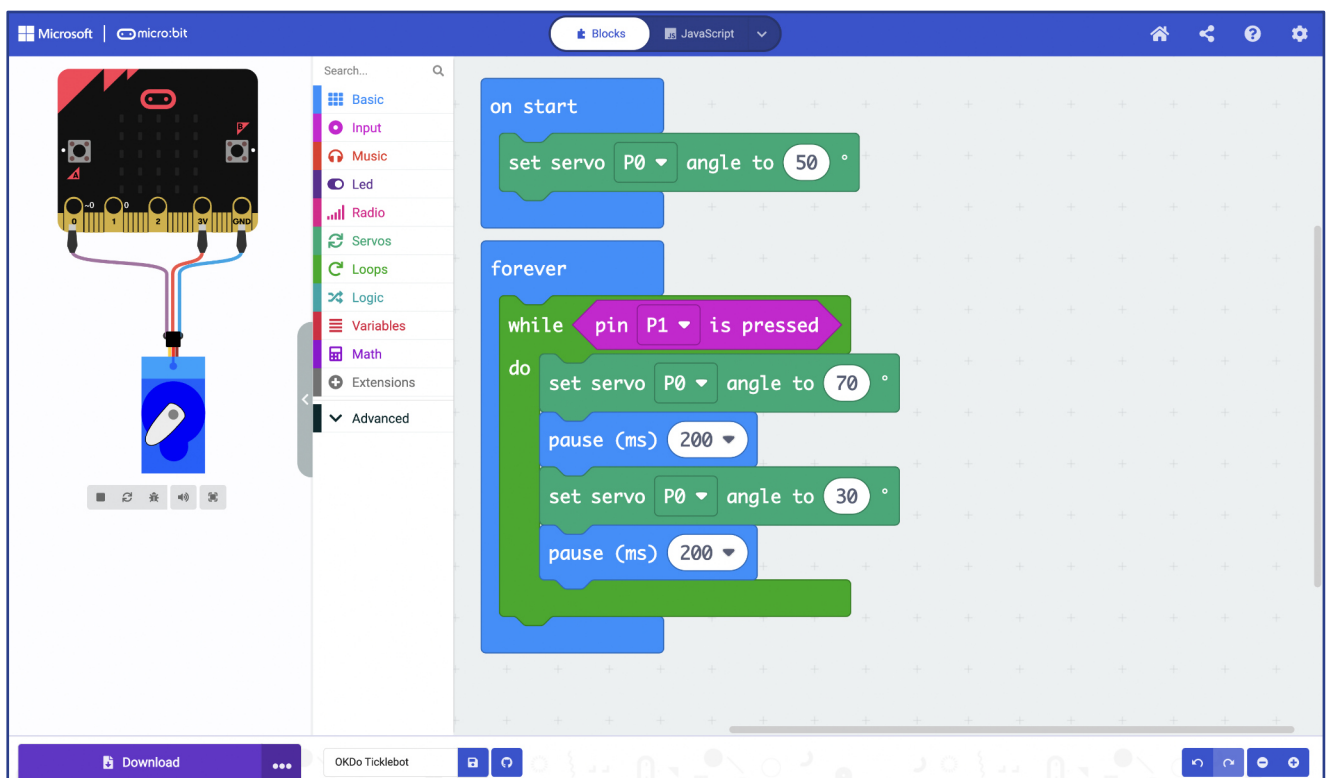

8

Test it out! Tickle Cheerbot's foot (make sure you're touching the tin foil or the conductive tape) to make it move. Here's a video of it in action:

https://youtu.be/Jdin_PYYk_8



You can also make the original 2-servo version of the Ticklebot with these tutorials:

<https://www.jasmineflorentine.com/ticklebot>

<https://learn.browndoggadgets.com/Guide/Ticklebot/303>